

Overview

- The **BA/#-P-x** is a Stainless Steel Replacement probe for use with any BAPI Immersion, or Duct temperature sensor. They come in a variety of lengths and with TFE insulated plenum cable. The **BA/#-P-x** sensor is available in multiple types of thermistor's or RTD temperature sensors as shown in the specifications. The probe comes without a box and is made to insert into an existing duct or immersion box fitting as a replacement. It is ideal to replace a damaged probe or to change the length of an existing probe installation.
- The **BA/#-HxP** is a Humidity Replacement probe w/sintered filter for use with any BAPI Duct or OSA RH transmitter. They come pre-calibrated and ready to install and use. The **BA/#-HxP** probe is available with multiple types of thermistor's or RTD temperature sensors as shown in the specifications. The replacement probe comes without a box and is made to thread into an existing duct or OSA enclosure. It is ideal to replace a damaged probe or worn-out sensor in an existing installation. Replacement 100 micron SS sintered filters as well as wash down caps are also available. No field calibration is required.
- The **BA/#-HxS** is a Humidity Sensor Replacement for BAPI room RH transmitters. They come pre-calibrated and ready to install and use. No field calibration is required.

Identification

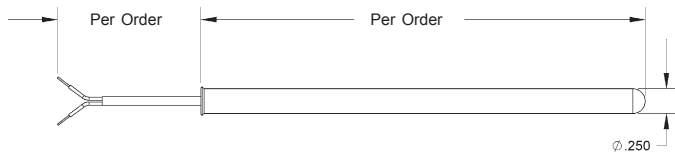

Fig 1: SS Replacement Sensor Probe (BA/#-P-X)

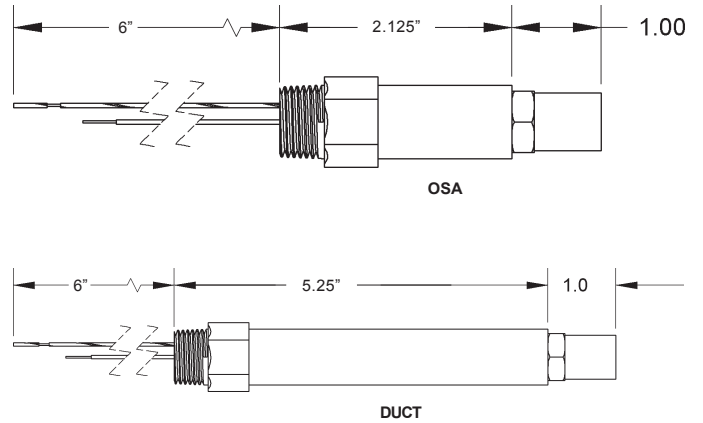

Fig 2: Replacement RH Probe (BA/#-HxP)

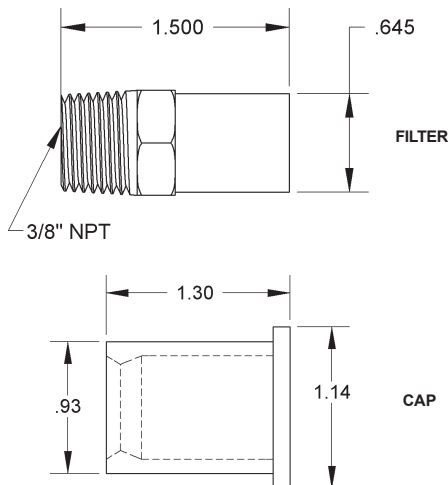

Fig 3: Replacement Sintered Filter & Washdown Cap (BA/HDOFS), (BA/VFC)

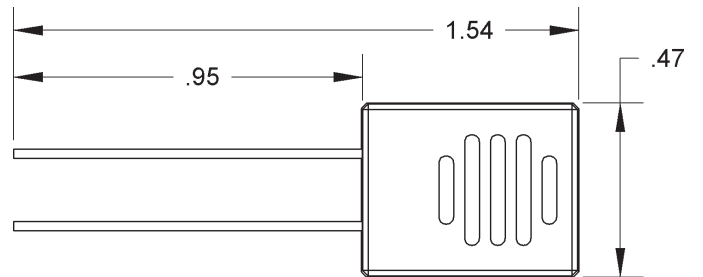

Fig 4: Replacement Room RH Sensor (BA/#-HxS)

Specifications subject to change without notice.

Mounting

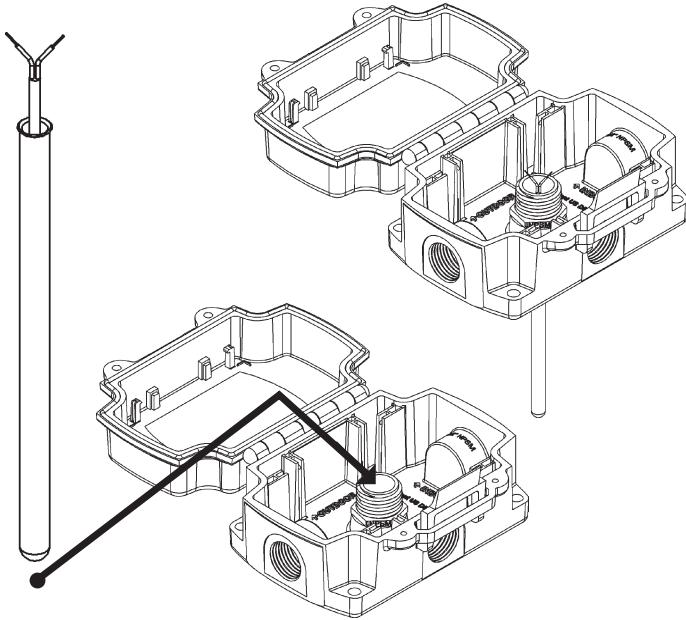

Fig 5: Typical Temperature Sensor probe replacement

1. Open the box and disconnect the wires.
2. Push the old probe into the box and out through the plastic fitting.
3. Push the new probe into the box and into the plastic fitting all the way to the flared end.
4. Pull the probe to full extension and re-connect per termination section.

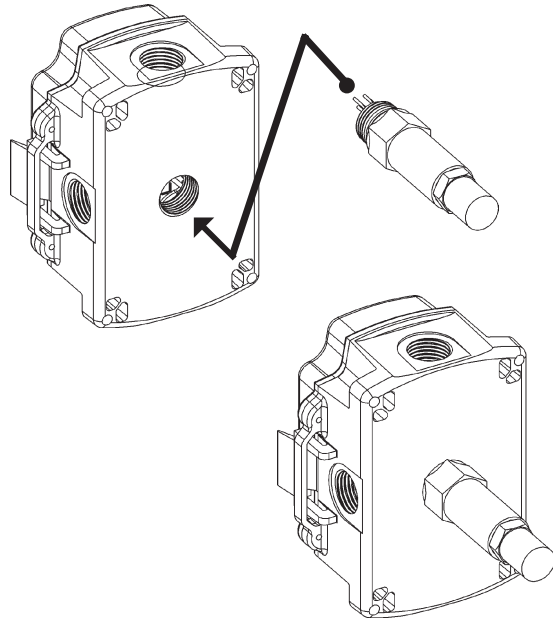

Fig 6: Typical Humidity Transmitter Probe Replacement

1. Un-install the box and disconnect the wires from the transmitter.
Note color code.
2. Un-screw (CCW) the old 1/2" NPT probe from the back of the box.
3. Screw in (CW) the new 1/2" NPT probe into the back of the box.
4. Install and re-connect the wires per the color code and termination section.

NOTE: No calibration is needed.

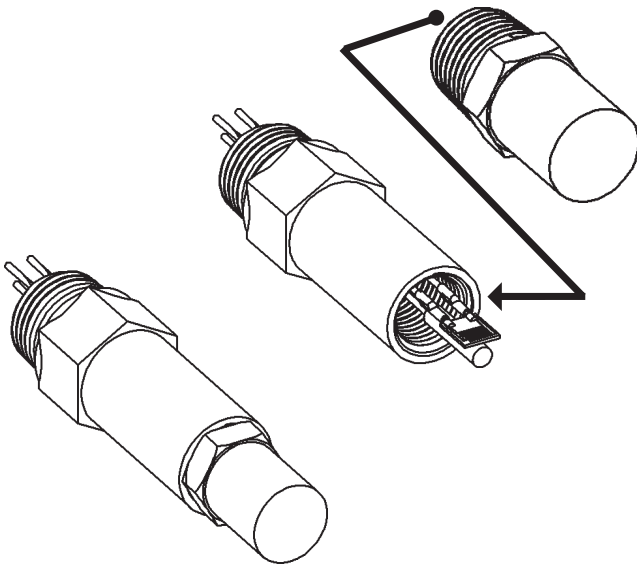

Fig 7: Typical Humidity Probe Filter Replacement

1. Un-screw (CCW) the old 1/2" stainless steel filter.
 2. Fully screw in (CW) the new 1/2" stainless steel filter.
- NOTE:** The old filter can be cleaned for future use with soap & water and then rinse thoroughly.

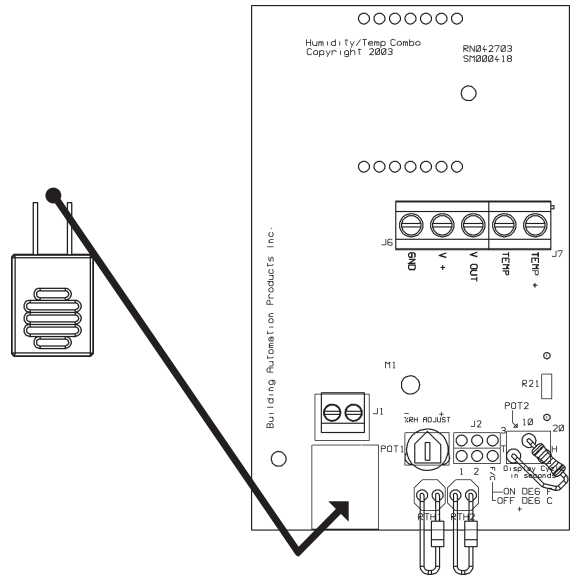
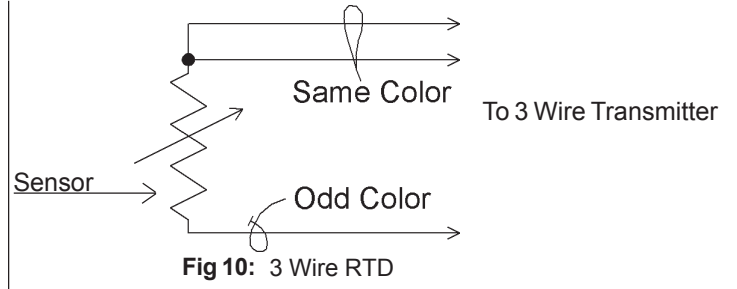
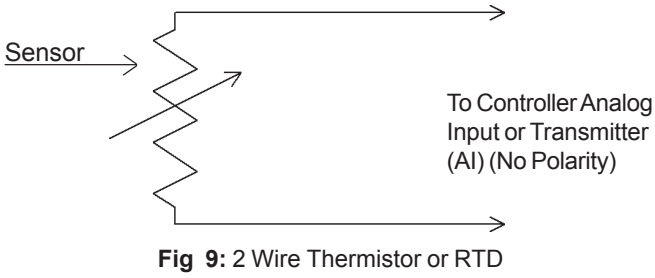

Fig 8: Typical Room RH Sensor Replacement

1. Take the sensor cover off using a 1/16" Allen wrench.
2. Un-screw terminals J1 and remove the old blue RH sensor.
3. Install new sensor leads in the terminals with vents facing up.
4. Install the sensor cover.

NOTE: No calibration is required.

Temperature Probe Termination



RH Probe Termination

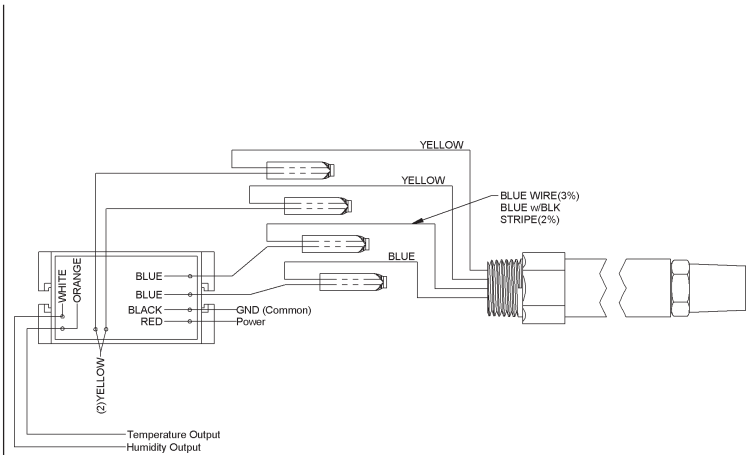
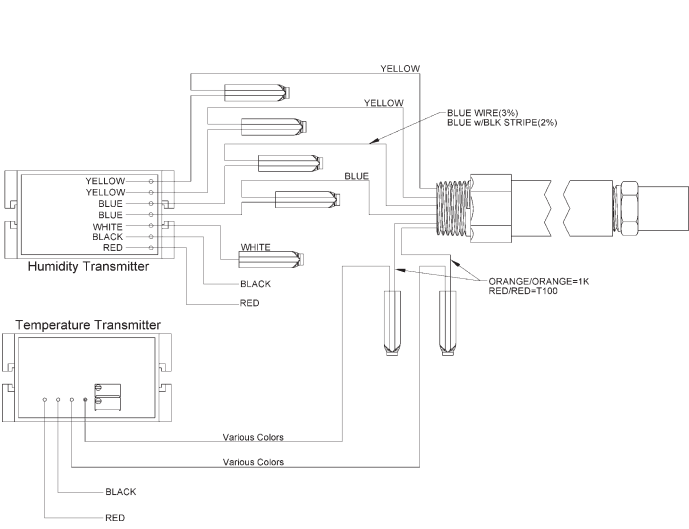

RH Probe Termination

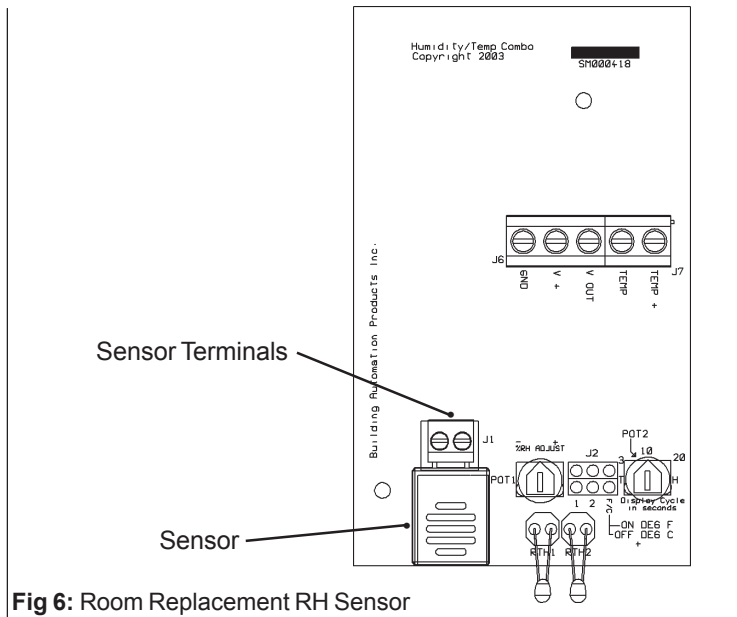
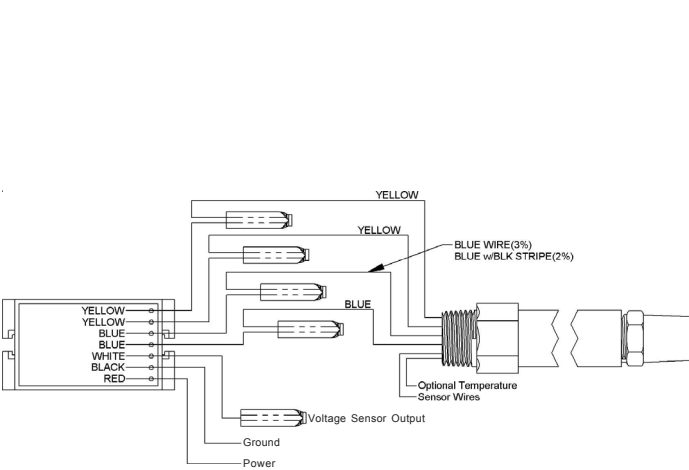

Specifications subject to change without notice.



Diagnosics

Problems:

Controller reports higher or lower than actual temperature

Humidity not reading

Humidity Sensor/Transmitter Check:

Possible Solutions:

- Confirm the input is set up correctly in the front end software
- Check wiring for proper termination & continuity. (shorted or open)
- Disconnect wires and measure sensor resistance and verify "Sensor" output is correct.
- Check power supply/controller voltage supply
- Disconnect humidity transmitter and check for correct power
- Connect power and then check signal wiring with a meter.
- Check for proper signal wiring to the controller.
- Open one of the blue wire connections. The transmitter should read 0% RH, if not the transmitter may be bad.
- Short out the blue wires. The transmitter should read 100% RH. If not the transmitter may be bad.
- Reconnect all the wires as shown in the wiring details for your sensor type and power up the transmitter. You should be reading the relative humidity at the output. Check this reading with a trusted hygrometer reference. If it's off by more than the added \pm accuracy of the hygrometer accuracy plus the transmitter accuracy the combined sensor/transmitter is bad or needs factory calibration. ($\pm 2\% + \pm 3\% = \pm 5\%$ total accuracy)

Specifications

Temperature Sensor:

Thermistor	NTC, 2 wire
RTD	PTC, 2 or 3 wire
Thermistor	Thermal resistor
Temp. Output	Resistance
Accuracy (std)	$\pm 0.36^\circ\text{F}$, ($\pm 0.2^\circ\text{C}$)
Accuracy (Hi)	$\pm 0.18^\circ\text{F}$, ($\pm 0.1^\circ\text{C}$), [XP] option
Stability	$< 0.036^\circ\text{F}/\text{Year}$, ($< 0.02^\circ\text{C}/\text{Year}$)
Heat dissipation	2.7 mW/ $^\circ\text{C}$
Temp. Drift	$< 0.02^\circ\text{C}$ per year
Probe range	-40° to 221°F (-40° to 105°C)
RTD	Resistance Temperature Device
Platinum (PT)	100 Ω or 1K Ω @ 0°C , 385 curve,
Platinum (PT)	1K Ω @ 0°C , 375 curve
PT Accuracy (std)	0.12% @Ref, or $\pm 0.55^\circ\text{F}$, ($\pm 0.3^\circ\text{C}$)
PT Accuracy (Hi)	0.06% @Ref, or $\pm 0.277^\circ\text{F}$, ($\pm 0.15^\circ\text{C}$), [A]option
PT Stability	$\pm 0.25^\circ\text{F}$, ($\pm 0.14^\circ\text{C}$)
PT Self Heating	0.4 $^\circ\text{C}/\text{mW}$ @ 0°C
PT Probe range	-40° to 221°F (-40° to 105°C)
Nickel (Ni)	1000 Ω @ 70°F , JCI curve
Ni Probe range	-40° to 221°F (-40° to 105°C)
Sensitivity	bapihvac.com click "Sensor Specs"
Thermistor	Non-linear
RTD (PT)	3.85 $\Omega/^\circ\text{C}$ for 1K Ω RTD 0.385 $\Omega/^\circ\text{C}$ for 100 Ω RTD
Nickel (Ni)	2.95 $\Omega/^\circ\text{F}$ for the JCI RTD
Lead wire	22awg stranded
Wire Insulation	FEP jacketed plenum rated cable
Probe	Rigid, 304 Stainless Steel, 0.25" OD
Mounting	Inserted into Plastic Fitting
Agency	RoHS, CE PT= DIN43760, IEC Pub 751-1983, JIS C1604-1989

RH Sensor and Probe:

Sensor:	Humidity	Resistive (Impedance)
	Temp.	Per sensor spec above
Filter:		100 micron sintered stainless steel
Wiring:	Duct Probe	RH- 4 flying leads, Opt. Temp.- 2 flying leads
	OSA Probe	RH- 4 flying leads, Opt. Temp.- 2 flying leads
	Room	Board mounted Terminals
Probe Termination Required:		Sealant filled crimp connectors, (BA/SFC1000-100)
Accuracy:	H2P, H2S	2%, from 15% to 95%RH @ 77°F
	H3P, H2S	3%, from 15% to 95%RH @ 77°F
Probe Material:	Duct	ABS Plastic, UL94V-HB
	OSA	Polycarbonate, UV resistant, UL94V-HB
Environmental Ambient Range:		-22° to 158°F , (-30° to 70°C) 0% to 100% RH